

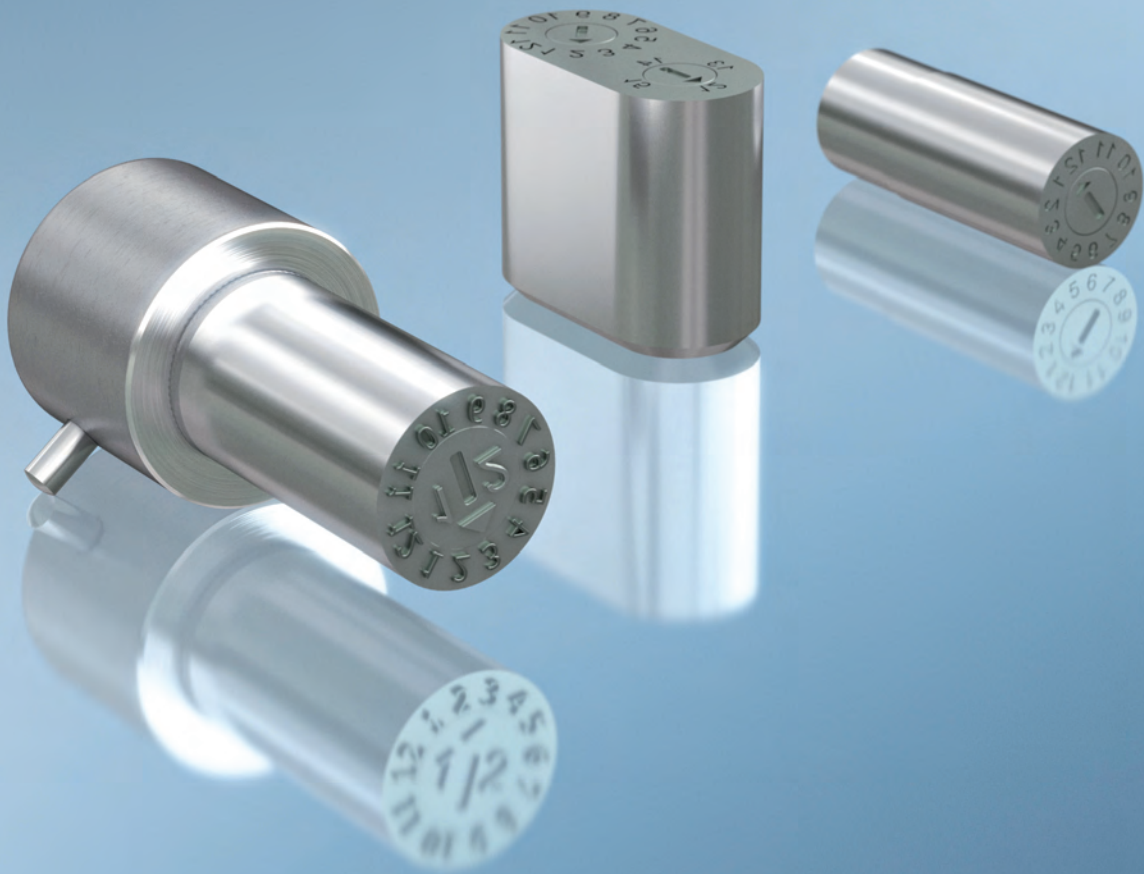









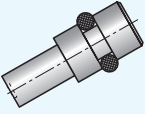

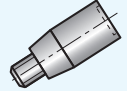
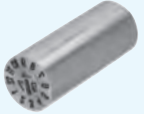

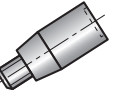
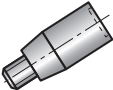

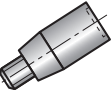
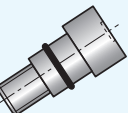
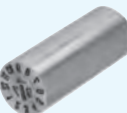

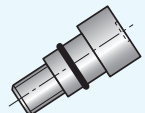

STRACK[®]
NORMALIEN

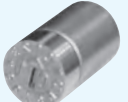

**DATUMSTEMPEL, PRÄGESTEMPEL
DATE INSERTS, EMBOSSING STAMPS
DATEURS, TAMPONS DATEUR AVEC GRAVURE EN RELIEF**

2

					
Z 5147-9 2.80	Z 5148-18 2.80	Z 5150-3 2.81	Z 5155-6 2.81	Z 5156-3 2.82	Z 5157-5 2.82
					
Z 5158-5 2.82	Z 5159-3 2.82	Z 5156-4 2.83	Z 5157-8 2.83	Z 5158-8 2.83	Z 5159-4 2.83
					
Z 5156-3,5 2.84	Z 5157-3,5 2.84	Z 5158-3,5 2.84	Z 5159-3,5 2.84	Z 5163 2.86	Z 5178 2.86
					
Z 5160 2.86	Z 5174-6 2.87	Z 5177-10 2.87	Z 5205 2.88	Z 5201 2.89	Z 5202 2.90
					
Z 5200 2.90	Z 5204 2.90	Z 5270 2.91			

2

Multimarker

Multimarkers

Poinçons de marquage multiple

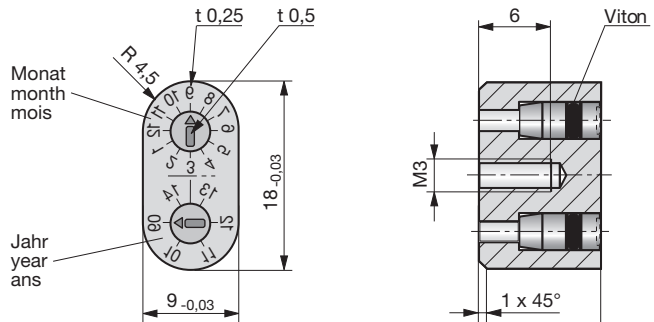

Z 5147-9

Mat.: 1.2343
~50HRC

t = Schrifftiefe / Depth of characters / Profondeur de la gravure

Z 5147-9

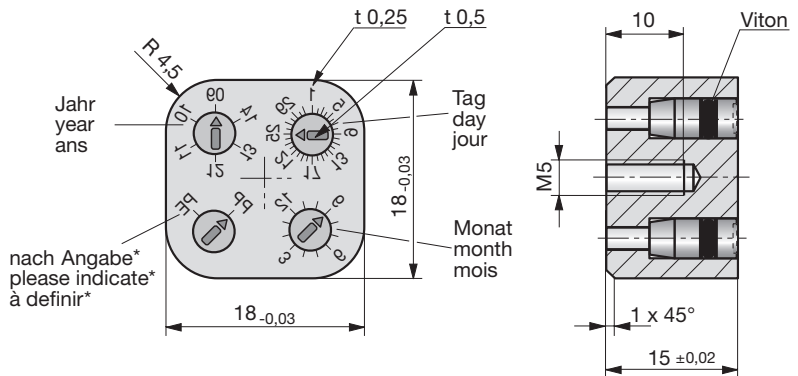
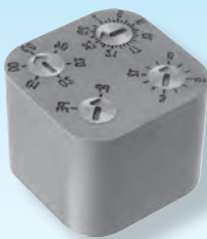

Z 5148-18

Mat.: 1.2343
~50HRC

t = Schrifftiefe / Depth of characters / Profondeur de la gravure

Z 5148-18-Mat



Material	Material	Materiaux
Kunststoff-Kurzzeichen	Plastic-symbol for basic polymers	Sigle des matières plastiques
*Bitte Material-Kurzzeichen angeben.	*Please indicate material abbreviation.	*Merci d'indiquer le sigle de la matière,
4 Kurzzeichen max. möglich.	4 abbreviations max. possible.	4 caractères maximum.

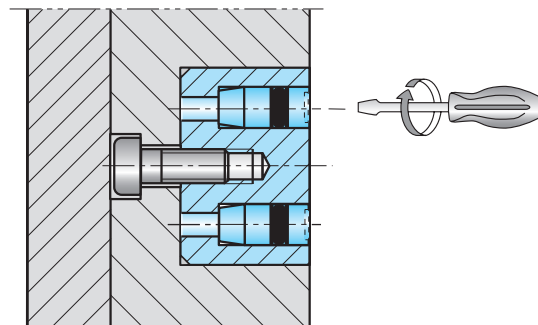

Datumsstempel

Date inserts

Dateurs

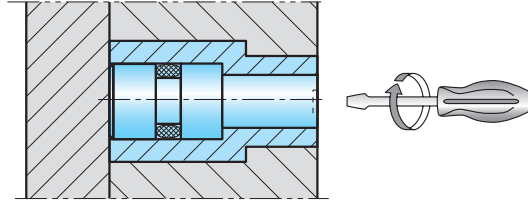

t = Schrifftiefe / Depth of characters / Profondeur de la gravure

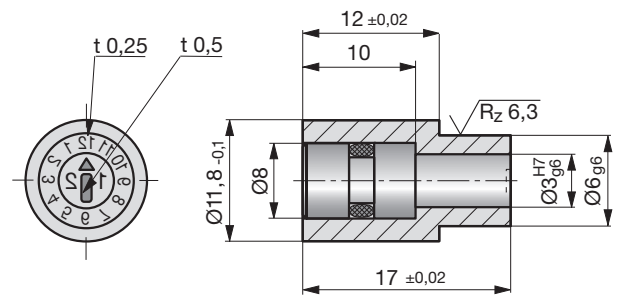
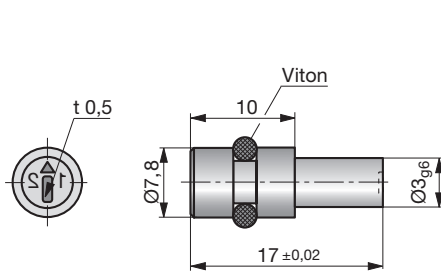

Z 5150-3-

Mat.: 1.2842
~60HRC

Z 5155-6-

Mat.: 1.2842
~60HRC



a

laufendes Jahr / current year / année courante

a

laufendes Jahr / current year / année courante

Datumsstempel

Date inserts

Dateurs

2

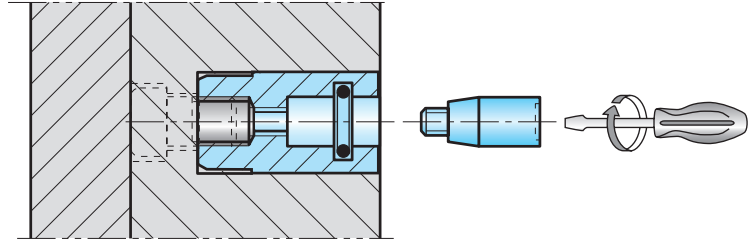
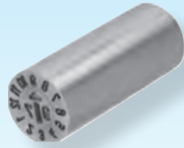

t = Schrifttiefe / Depth of characters / Profondeur de la gravure

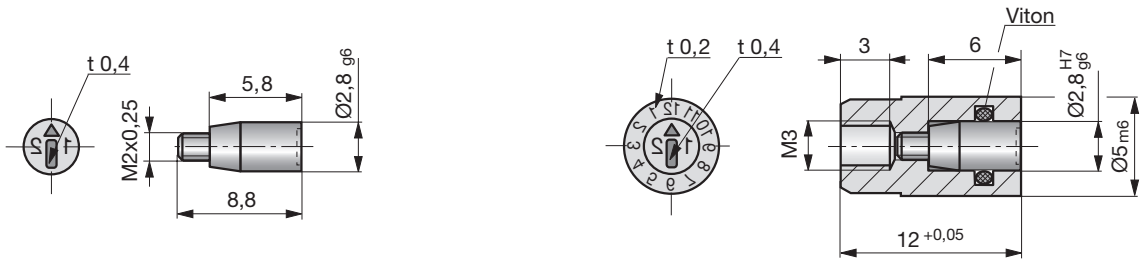

Z 5156-3-

Mat.: 1.2842
~60HRC

Z 5157-5-

Mat.: 1.2842
~60HRC



a

laufendes Jahr / current year / année courante

a

laufendes Jahr / current year / année courante

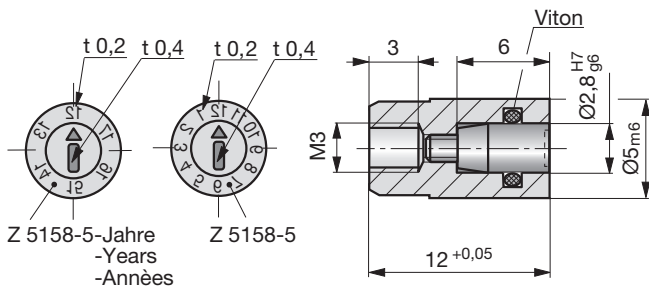

Z 5158-5-Jahre
-Years
-Années

Z 5158-5
Z 5158-5-

Mat.: 1.2842
~60HRC

Z 5159-3

Mat.: 1.2842
~60HRC

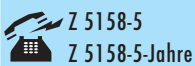

Z 5158-5

Z 5158-5-Jahre/Years/Années

-

12 - 17

-

13 - 18

Datumsstempel

Date inserts

Dateurs

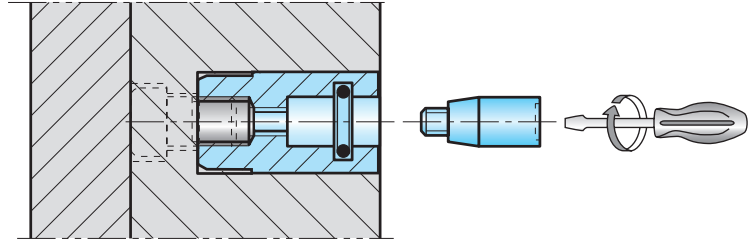
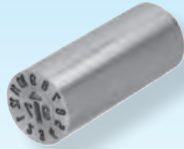

t = Schrifttiefe / Depth of characters / Profondeur de la gravure

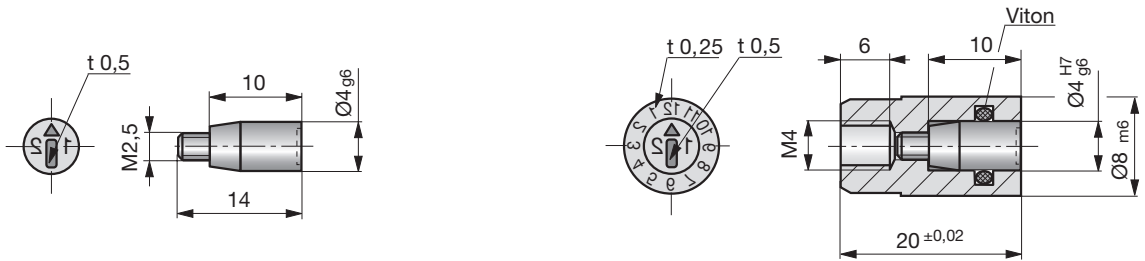

Z 5156-4-

Mat.: 1.2842
~60HRC



a

laufendes Jahr / current year / année courante

Z 5157-8-

Mat.: 1.2842
~60HRC



a

laufendes Jahr / current year / année courante

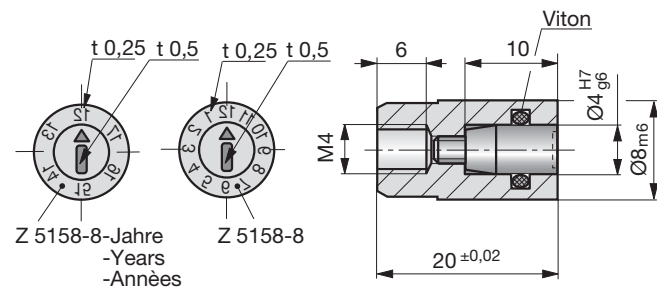

Z 5158-8
Z 5158-8-

Mat.: 1.2842
~60HRC

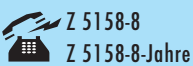

Z 5158-8

Z 5158-8-Jahre/Years/Années

—

12 - 17

—

13 - 18

Z 5159-4

Mat.: 1.2842
~60HRC



Datumsstempel

Date inserts

Dateurs

2

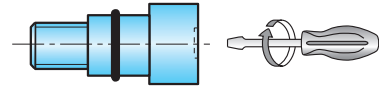
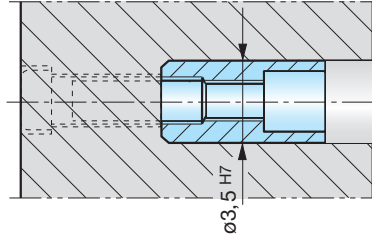
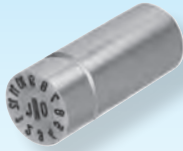

Markierung in Werkzeugkontur einbringen
Insert marking in the tool contour
Poser marque dans le contour de l'outil

t = Schrifttiefe / Depth of characters / Profondeur de la gravure

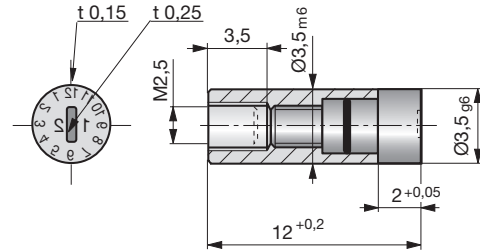
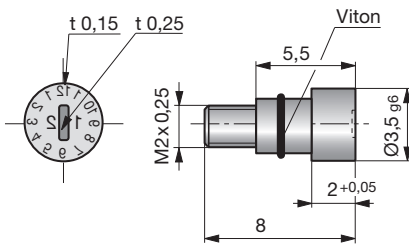
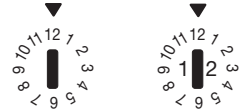

Z 5156-3,5-

Mat.: 1.2162
~56HRC

Z 5157-3,5-

Mat.: 1.2162
~56HRC

 Z 5156-3,5-a



 Z 5157-3,5-a



a

laufendes Jahr / current year / année courante

a

laufendes Jahr / current year / année courante

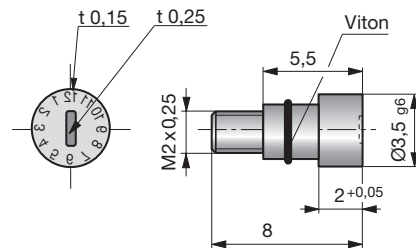
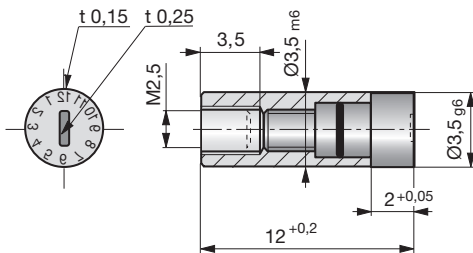

Z 5158-3,5

Mat.: 1.2162
~56HRC

Z 5159-3,5

Mat.: 1.2162
~56HRC

 Z 5158-3,5



 Z 5159-3,5



Datumsstempel

Date inserts

Dateurs

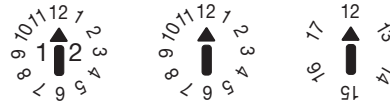
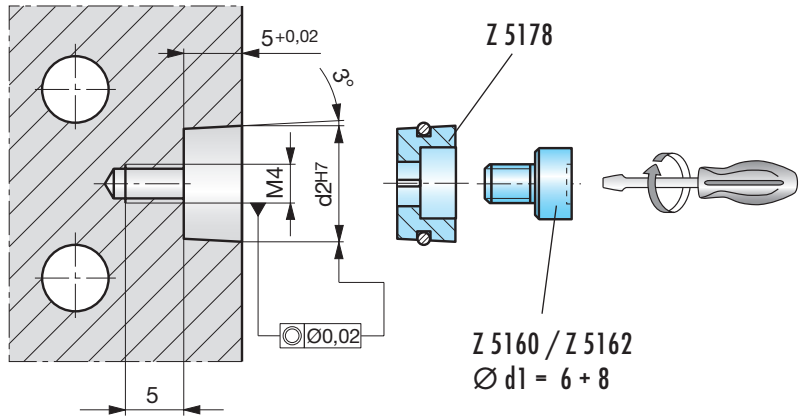

t = Schrifftiefe / Depth of characters / Profondeur de la gravure

MONTAGEANWEISUNG

FITTING INSTRUCTIONS

MONTAGE

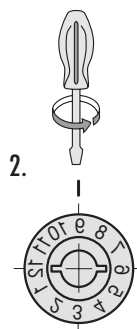
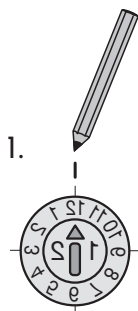

1. - Prägestempel komplett montieren,
- Pfeilrichtung markieren
2. - Innenteil Z 5201 / Z 5208 ausschrauben,
- Hülse Z 5202 zur Markierung in Position drehen
3. - Innenteil Z 5201 / Z 5208 einschrauben,
- Position überprüfen

1. - Fully mount embossing stamp,
- Mark arrow direction
2. - Unscrew inner part Z 5201 / Z 5208,
- Rotate sleeve Z 5202 into position for marking
3. - Screw in inner part Z 5201 / Z 5208,
- Check position

1. - Monter l'ensemble dateur,
- Repérer le sens de la flèche.
2. - Dévisser l'insert Z 5201 / Z 5208,
- Tourner le corps pour amener le
chiffre Z 5202 en face du repère
3. - Revisser l'insert Z 5201 / Z 5208,
- Vérifier l'alignement

Datumsstempel
Date inserts
Dateurs

2

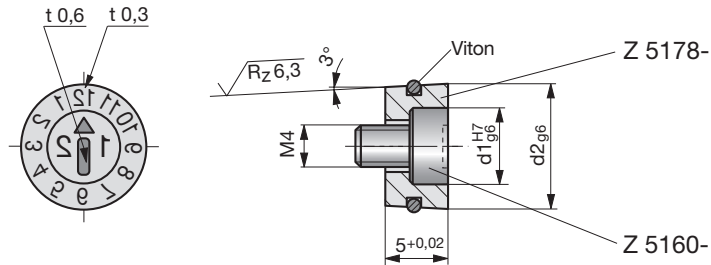
Z 5163-

 Mat.: 1.2842
 ~60HRC

 Z 5163-d2-b-a

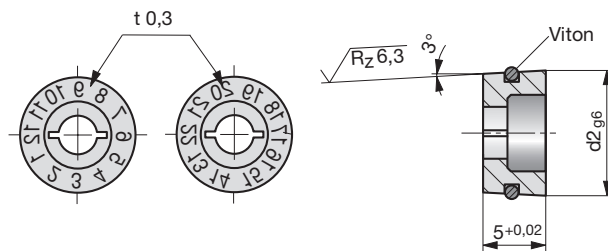

d2	b	a	d1	d2	b	a	d1
10	1 - 12	laufendes Jahr	6	14	1 - 12	laufendes Jahr	8
	13 - 22	current year	6		13 - 22	current year	8
	23 - 32	année courante	6		23 - 32	année courante	8
	33 - 42		6		33 - 42		8
	43 - 52		6		43 - 52		8

Z 5178-

 Mat.: 1.2842
 ~60HRC

 Z 5178-d2-b

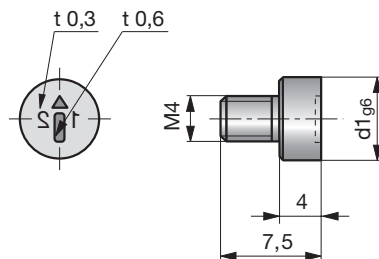
d2	b	d2	b
10	1 - 12	14	1 - 12
	13 - 22		13 - 22
	23 - 32		23 - 32
	33 - 42		33 - 42
	43 - 52		43 - 52

Z 5160-

 Mat.: 1.2842
 ~60HRC

 Z 5160-d1-a

d1	a
6	laufendes Jahr
8	current year
10	année courante

Prägestempel

Embossing stamps

Tampons dateur avec gravure en relief

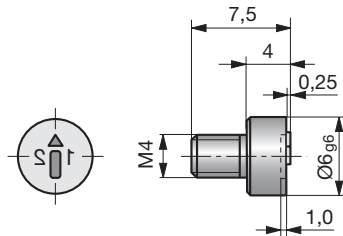
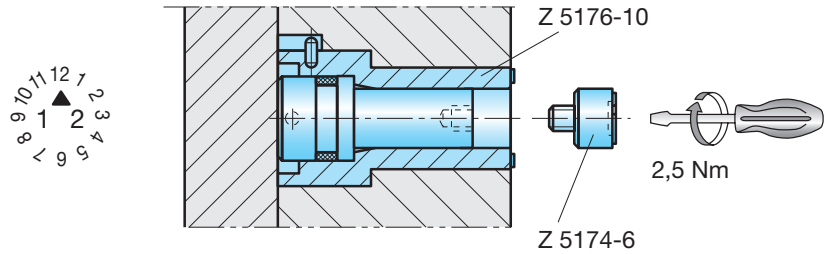

Z 5174-6-

Mat.: 1.2379
~ 60HRC



Z 5174-6-a



a

laufendes Jahr
current year
année courante

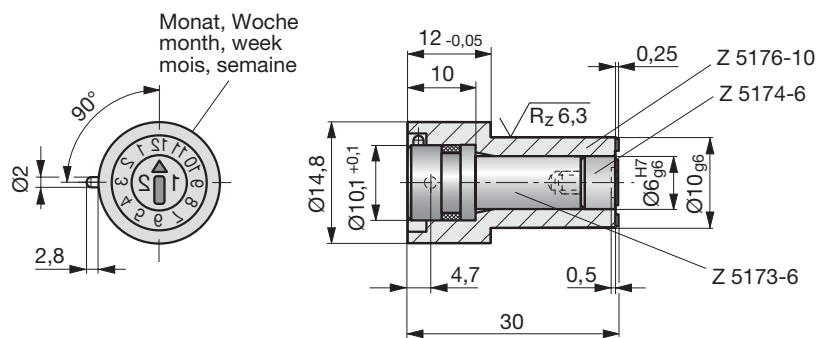

Z 5177-10-

Mat.: 1.2162 / 1.2379
~ 60HRC



Z 5177-10-b-a



b

1 - 12
13 - 22
23 - 32
33 - 42
43 - 52

a

laufendes Jahr
current year
année courante

Prägestempel

Embossing stamps

Tampons dateur avec gravure en relief

2

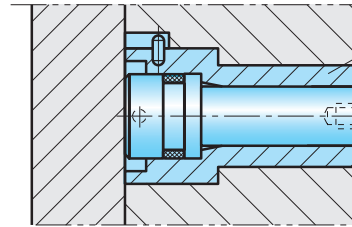

Z 5207-10
Z 5207-14

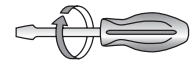

2,5 Nm

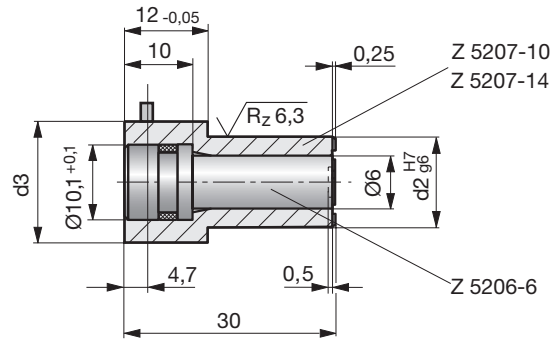
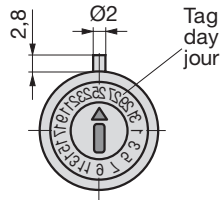

Z 5205-

Mat.: 1.2379
~60HRC

d2

d3

10

14,8

14

18

 Z 5205-d2



Prägestempel

Embossing stamps

Tampons dateur avec gravure en relief

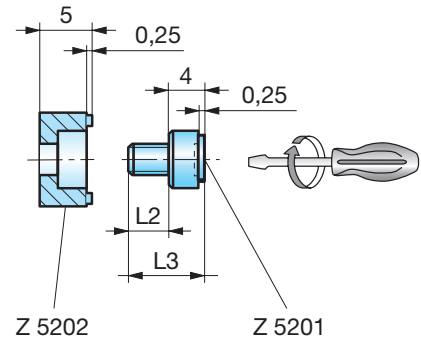
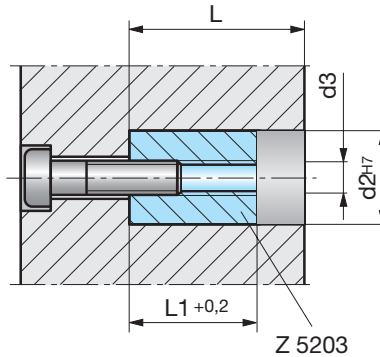
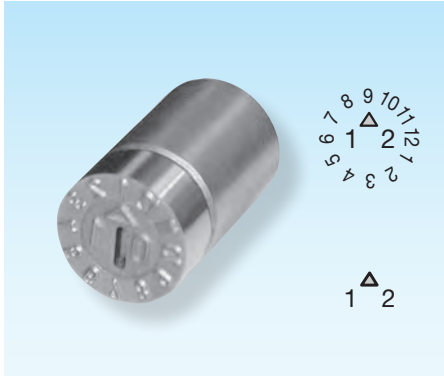

2

Montageanweisung

Installation instruction

Instruction de montage

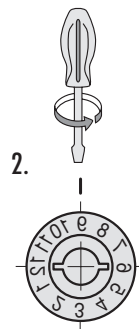

1. - Prägestempel komplett montieren,
- Pfeilrichtung markieren
2. - Innenteil Z 5201/ Z 5208 ausschrauben,
- Hülse Z 5202 zur Markierung in Position drehen
3. - Innenteil Z 5201/ Z 5208 einschrauben,
- Position überprüfen

1. - Fully mount embossing stamp,
- Mark arrow direction
2. - Unscrew inner part Z 5201/ Z 5208,
- Rotate sleeve Z 5202 into position for marking
3. - Screw in inner part Z 5201/ Z 5208,
- Check position

1. - Monter l'ensemble dateur,
- Repérer le sens de la flèche.
2. - Dévisser l'insert Z 5201/ Z 5208,
- Tourner le corps pour amener le chiffre Z 5202 en face du repère
3. - Revisser l'insert Z 5201/ Z 5208,
- Vérifier l'alignement

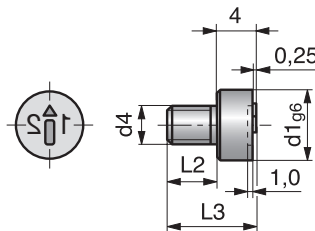

Z 5201-

Mat.: 1.2379
~ 60HRC

 Z 5201-d1-a



d1

3,5

6

a

laufendes Jahr
current year
année courante

L2

4,5

6

L3

8,5

10

d4

M2,5

M4

Prägestempel

Embossing stamps

Tampons dateur avec gravure en relief

2

Monat, Woche (Tag)
month, week (day)
mois, semaine (jour)

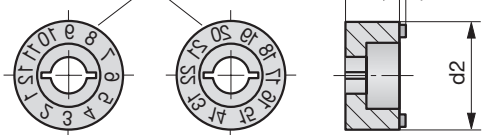

Z 5202-

Mat.: 1.2379
~ 60HRC

Z 5202-d2-b



d2	b
6 / 10	1 - 12
	13 - 22
	23 - 32
	33 - 42
	43 - 52

Z 5200



Z 5204

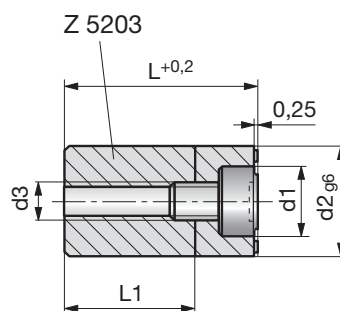

Z 5200-

Mat.: 1.2162/1.2379
~ 60HRC

Z 5200-d2-b-a



d2	b	a	L	L1	d3
6	1 - 12	laufendes Jahr	14	9	M3
	13 - 22	current year	14	9	M3
	23 - 32	année courante	14	9	M3
	33 - 42		14	9	M3
	43 - 52		14	9	M3
10	1 - 12		17	12	M4
	13 - 22		17	12	M4
	23 - 32		17	12	M4
	33 - 42		17	12	M4
	43 - 52		17	12	M4

Z 5204-

Mat.: 1.2162/1.2379
~ 60HRC

Z 5204-d2-b



d2	b	L	L1	d3
6	1 - 12	14	9	M3
	13 - 22	14	9	M3
	23 - 32	14	9	M3
	33 - 42	14	9	M3
	43 - 52	14	9	M3
10	1 - 12	17	12	M4
	13 - 22	17	12	M4
	23 - 32	17	12	M4
	33 - 42	17	12	M4
	43 - 52	17	12	M4

Endkontrollstempel

Final inspection stamp

Timbre du contrôle final

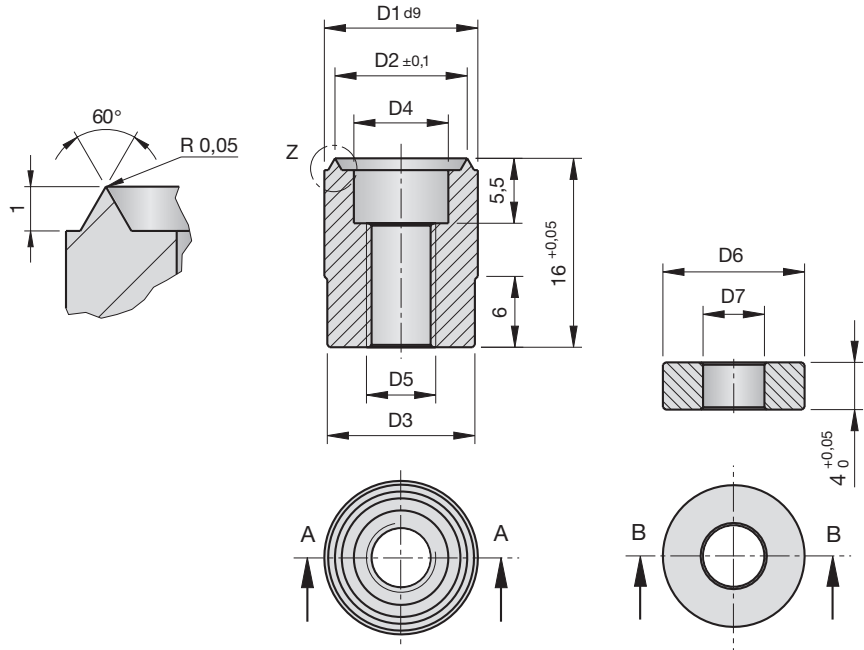
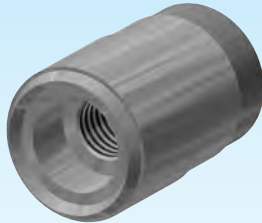

SN 5270-

Mat. 1.2210
60 ±2HRC

 SN 5270-D1



D1	D2	D3	D4	D5	D6	D7	D8
10	8,0	9,5	6	M4	10	4,2	M3
13	11,2	12,5	8	M5	12	5,2	M4

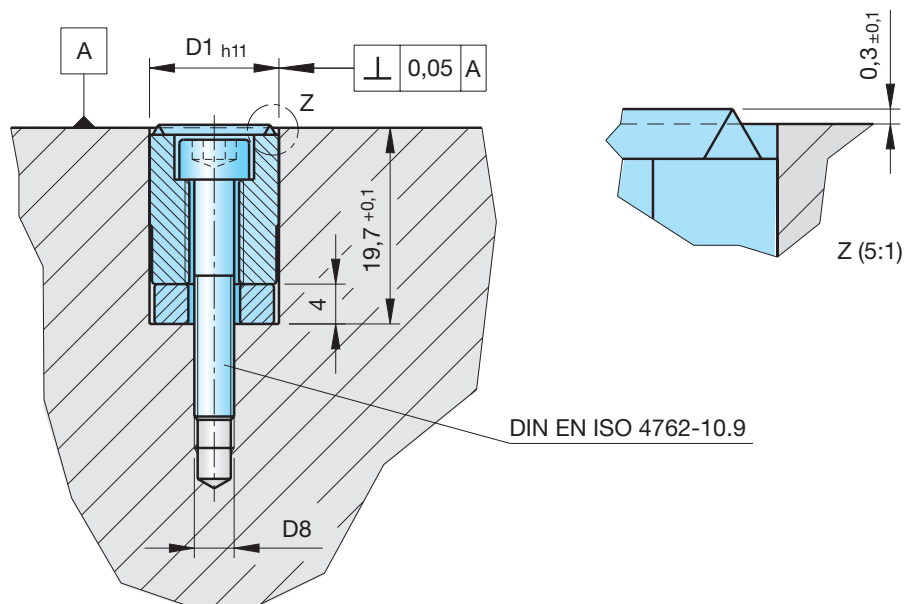



INGENIERIA DE MOLDES Y TROQUELES, S. A.

STRACK[®]
NORMALIEN

Allgemeines Zubehör / General accessories / Accessoires généraux

www.strack.de

2